

# AMBER SELECT / AMBER SELECT<sup>X</sup>

## Setting Up Your System



## Quick Start Guide

To set up your system, follow the steps below. For more detailed information, see the AMBER SELECT / AMBER SELECT<sup>X</sup> User Guide.

Select a central location in your home for the AMBER SELECT / AMBER SELECT<sup>X</sup> where you spend most of your time. The AMBER SELECT / AMBER SELECT<sup>X</sup> can be placed on a table, desk, or counter. It also can be mounted on the wall.

### 1. Connect the Base Unit to your Telephone Line:

Connect the wide end (RJ-45) of the phone cord to the "Wall Jack" on your AMBER SELECT / AMBER SELECT<sup>X</sup>. Plug the narrow end (RJ-11) of that phone cord into the phone jack on your wall.

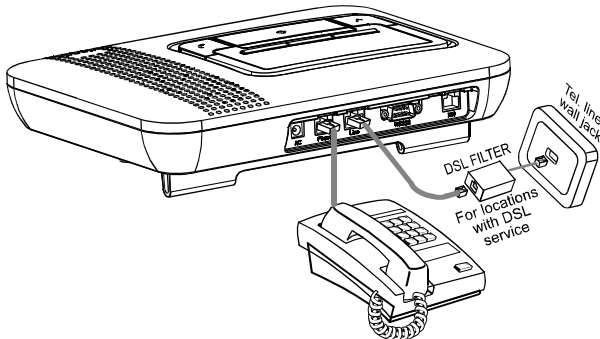

**Note:** Be aware of other phone line services such as DSL. If DSL service is present on the phone line, you must install a filter. For more information regarding the DSL filter, contact the service provider.

INSERT THE SAFETY CATCH TAB HORIZONTALLY AS SHOWN.  
TURN THE LEFT SIDE OF THE CATCH COUNTER-CLOCKWISE  
UNTIL IT FACES THE SCREW HOLE AND THEN FASTEN THE  
SAFETY CATCH WITH THE SCREW

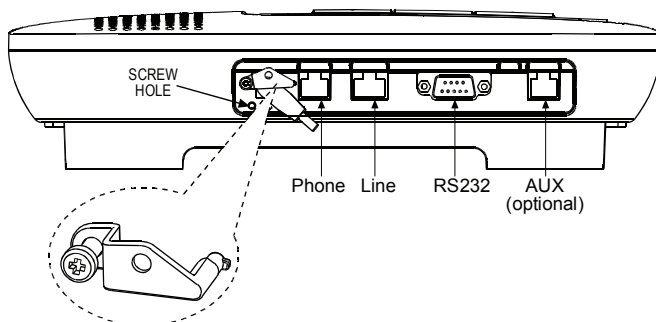

**Note:** The safety catch is optional, can be purchased upon request.

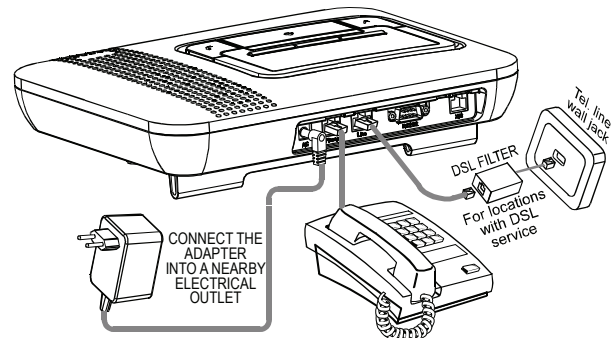

### WARNING!

DO NOT USE AN OUTLET CONTROLLED BY A WALL SWITCH.

When electrical power is supplied to the Base Unit, the green light on the front panel illuminates.

**Note:** It is recommended that the AC power input, the RS-232, and the telephone be interconnected within the same room.

### 2. Program the panel:

#### Local setup

Install the HHCP software on your PC. Enter all the desired programming information into the HHCP. Connect one end of the special cable (supplied by Visonic) to one of the computer's COM ports and the other end to the AMBER SELECT / AMBER SELECT<sup>X</sup> unit.

#### Remote setup

Enter all the desired programming information into the HHCP. Connect to the remote panel via a dial-up modem attached to the PC.

### 3. The AMBER SELECT / AMBER SELECT<sup>X</sup> will call the Central Station:

After you complete steps 1 and 2 above your AMBER SELECT / AMBER SELECT<sup>X</sup> will automatically call your Central Station provided that your unit was programmed to report to Central Station (and not to private telephones). The central station operator will begin a two-way voice session. Once this feature has been tested, the operator must disconnect by pressing DTMF '99'.

**Note:** Certain remote areas of your residence may lie outside the reception range of the AMBER SELECT / AMBER SELECT<sup>X</sup>, resulting in the unit not being able to receive transmissions directly. In this case, a Repeater (MCX-600PERS) can be used to increase the AMBER SELECT / AMBER SELECT<sup>X</sup> reception range.



#### W.E.E.E. Product Recycling Declaration

For information regarding the recycling of this product you must contact the company from which you originally purchased it. If you are discarding this product and not returning it for repair then you must ensure that it is returned as identified by your supplier. This product is not to be thrown away with everyday waste.  
Directive 2002/96/EC Waste Electrical and Electronic Equipment.



VISONIC LTD. (ISRAEL): P.O.B 22020 TEL-AVIV 61220 ISRAEL. PHONE: (972-3) 645-6789, FAX: (972-3) 645-6788  
VISONIC INC. (U.S.A.): 65 WEST DUDLEY TOWN ROAD, BLOOMFIELD CT. 06002-1376. PHONE: (860) 243-0833, (800) 223-0020. FAX: (860) 242-8094  
VISONIC LTD. (UK): 7 COPPERHOUSE COURT, CALDECOTTE, MILTON KEYNES. MK7 8NL  
VISONIC GmbH (D-A-CH): KIRCHFELDSTR. 118, D-40215 DÜSSELDORF, TEL.: +49 (0)211 600696-0, FAX: +49 (0)211 600696-19  
VISONIC IBERICA: ISLA DE PALMA, 32 NAVE 7, POLIGONO INDUSTRIAL NORTE, 28700 SAN SEBASTIAN DE LOS REYES, (MADRID), ESPAÑA. TEL (34) 91659-3120,  
FAX (34) 91663-8468. www.visonic-iberica.es  
INTERNET: www.visonic.com  
©VISONIC LTD. 2009 AMBER SELECT / AMBER SELECT<sup>X</sup> QUICK START GUIDE D-301439 (REV. 2, 5/09)



MADE IN  
ISRAEL